

# Instructions manual

**DEHUMID**

**HP50**



# Table of contents

1.	Unpacking	3
2.	Intended use	3
3.	Disposal	3
4.	Safety instructions	3
5.	Functional principle	4
6.	Automatic defrosting system	4
7.	Set up and transportation	4
8.	Operation	5
9.	Radio operation	6
10.	Overheating protection	6
11.	Keylock	6
12.	Operating hours counter	6
13.	Emptying the water tanks	6
14.	Operation with direct drain hose	6
15.	Maintenance	7
16.	Specifications	8
17.	Troubleshooting	8+9
18.	Circuit diagram	9
19.	Exploded view	10
20.	Subassemblies	11

Dear customer,

thank you for choosing the **DEHUMID HP 50**. You have purchased a high quality, state-of-the-art product.

Please read this instruction manual carefully, before putting the unit into service and keep it for future reference. This manual is supposed to help you to safely install, operate and maintain the **DEHUMID HP 50**.

Always pay attention to the safety advice indicated by this sign to prevent damage to persons and the device and to minimize downtime.



### 1. Unpacking

After receiving the unit, you should check your dehumidifier for any transport damage.

In case of damage, **DO NOT** put the device in operation. Instead, you should immediately contact your retailer.

Keep the packing of the unit in a safe place in order to be able to dispatch the appliance safely in case of warranty. In order to save space, you simply cut through the adhesive tape using a knife and fold up the cardboard box.

### 2. Intended use

The **DEHUMID HP 50** is solely designed to reduce the air humidity in closed rooms.

The dehumidifier can be used to counter the effects of humidity damage, or to protect rooms from mould, rust and other humidity-caused damages.

If it is being used for different purposes, the manufacturer will not assume liability for any damages that may arise.



**ATTENTION !**

**This dehumidifier is not suitable for continuous operation in swimming pools! It may be used there however, when there is no water in the basin.**

### 3. Disposal

This symbol on the device means that the device must not be disposed of with normal household waste.

It has to be delivered at a suitable collection site for recycling of electric appliances (e.g. recycling depot).

Through separate disposal you contribute to the protection of the environment and your fellow human beings, since a form of recycling is ensured, that is safe for man and environment.

You can obtain information on proper disposal from the local authorities or your retailer.



## 4. Safety instructions

**Keep away from children:** Do not allow children to play with, or around this unit. It may result in injury. Be sure the unit is inaccessible to children when they are unattended.

**Keep unit grounded:** Always operate the unit with a grounding plug and a grounded electrical outlet. A grounding plug is an essential safety feature that helps reducing the risk of shock or fire.

**Protect power cord from damage:** Never operate the unit with a damaged power cord, as this may lead to electrical or fire hazards. If the power supply cord is damaged, it must be replaced by a cord of the same type and specifications.

**Place on stable surface:** Always operate the unit on a stable, level surface, to prevent it from falling and cause injury.

**Keep away from water:** Never operate the unit in pooled or standing water, as this contains a risk of injury due to electrical shock. Do not store or operate it outdoors. If electrical wiring or components become wet, thoroughly dry them before using the unit.

**Keep air intakes clear:** Do not clog or block air intakes, which may occur if operated too close to draperies or similar materials. This may cause the unit to overheat and result in a fire or electrical hazard.

**Keep filters clean:** Always use clean air filters. Do not allow any material to clog the filter, as this may cause the dehumidifier to overheat. Do not allow oil, grease, or other contaminants to be drawn into the dehumidifier.

**Keep Electrical Components Dry:** Never allow water inside the dehumidifier's electrical components. If these areas become wet for any reason, thoroughly dry them before using the dehumidifier.



**ATTENTION !**

**This dehumidifier must not be used in rooms under the following conditions:**

- Potentially explosive atmosphere
- Aggressive atmospheres
- High concentration of solvents in the air
- An extremely high ratio of dust

## 5. Functional principle

This dehumidifier is designed to reduce humidity from the air in a building or part of a building. The purpose is to prevent humidity damage, and to dry out wet materials such as carpet, carpet cushion, floors, walls, furniture, contents, lumber, and structural materials.

This dehumidifier can avoid the formation of condensate, eliminate high air humidity and keep constant a certain humidity value. The time necessary for the dehumidifier to dry a room and to reach the air humidity level desired strongly depends on the environmental conditions prevailing at the site of installation of the appliance. The dehumidifier functions according to the condensation principle with heat recovery. The fan takes in the humid air through the evaporator. Here the air is cooled below the dew point so that the water vapor present in the air condensates and flows into the water collecting tank. The cooled and dried air is heated again at the condenser. By the permanent circulation of the ambient air through the appliance, the absolute humidity is decreased continuously.

## 6. Automatic defrosting system

During normal dehumidifying operation, ice may form on the evaporator. This dehumidifier is equipped with an automatic hot-gas defrosting system and if ice is detected by the temperature sensor, it will defrost automatically according to the following principle:

- A temperature sensor measures the condition existing in a critical area of the evaporator.
- It transmits the electrical signal for the defrosting system. It has been designed to avoid a frequent defrosting of the dehumidifier.
- After some time the relay will switch off the fan and simultaneously open a solenoid valve.
- Now, hot gas is channeled into the evaporator until the latter is completely free of ice.
- Subsequently, the dehumidifier will operate again in the normal mode.

## 7. Set up and transportation

Regarding set up and transportation the following instructions have to be followed:

- Make sure, that the air filters as well as the gratings, which are situated on the sides of the dehumidifier, are not covered!
- Before moving the device to a different location, switch it off using the mains switch! Unplug the cable and empty the water tanks (see 13.)!
- Place the dehumidifier on a level surface! If that is not possible, secure it against rolling away!
- Always transport the dehumidifier in an upright position!
- If, for any reason, the device has been positioned horizontally for even a few minutes, let it stand upright for at least 30 minutes afterwards, before switching it on again. This allows the oil to run back into the compressor.



### **ATTENTION !**

**The device must only be transported in an upright position. Small inclines when moving it with the wheels are uncritical. Bigger inclines should be avoided.**

**In case the device has been transported in a horizontal or strongly inclined position, it must rest upright for at least 30 minutes prior to putting it back into operation.**

**Before you move the device make sure that:**

- **the power cord has been unplugged,**
- **no water is left in the water tanks,**
- **the dehumidifier has rested for at least 5 minutes prior to transport.**

## 8. Operation

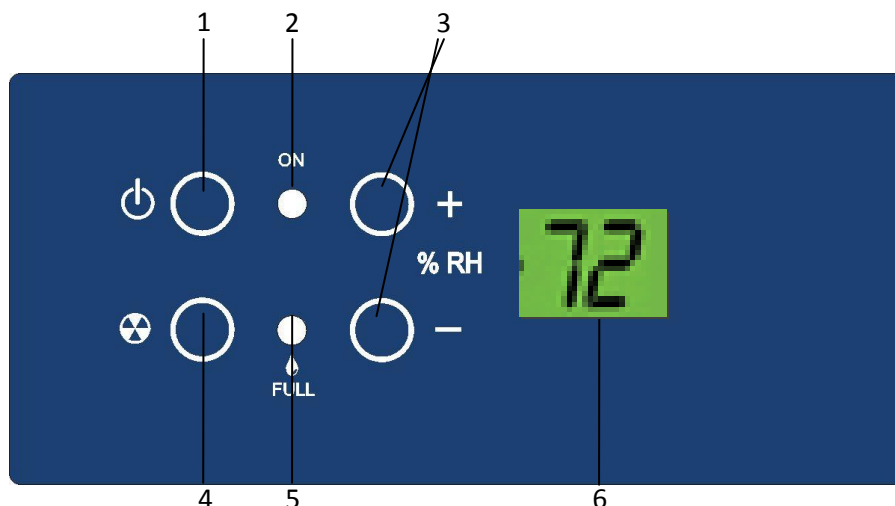

### 1) On/off switch

Puts the device into the standby mode and turns it back on.

### 2) LED „ON“

The LED „ON“ lights up, when the device is supplied with electrical power.

### 3) Control for relative humidity

Using the buttons „+ % RH“ and „- % RH“ you can preset the desired level of relative humidity.

Upon pressing either of these buttons the display switches from showing the actual value to showing the set value. Shortly after the desired value has been set, the display switches back to the current value.

You can adjust the desired value between 31-90 % rel. humidity. Once this value has been reached the device automatically switches off.

The dehumidifier switches on when the set value has been exceeded by +1 and switches off when the value falls below the set value by -2. The minimum running and pause times of the compressor is 1 minute each.

When you preset a level of 30% relative humidity the device will run in continuous operation **and will not switch off even when this value has been reached.**

### 4) Fan speed selector

The **DEHUMID HP 50** can run with two different fan speed stages.

When you change the setting the display will show the selected fan speed stage. After a short period of time it switches back to showing the current humidity value.

### Stage 1:

#### High performance

The fan is running at maximum speed. We recommend this setting when you desire a high and rapid dehumidification.

### Stage 2:

#### Low performance

The fan is running at reduced speed and therefore especially silently. However, the dehumidification performance is also being reduced.

### 5) LED „water tank full“

When the LED „FULL“ **lights up** the water tanks are either full or not inserted properly. The device then switches off automatically.

Empty the water tanks (see 13.) and make sure to correctly put them back into the dehumidifier. After a short period of time the device will then resume operation.

When removing the water tanks during operation the device will sound a bleep and stops running.

When the LED „FULL“ **flashes**, the device is set to operate with direct drain.

### 6) Display

By default the display shows the current actual humidity level.

When changing the fan stage it shows the selected stage.

When changing the desired humidity value the display shows that value.

If there is an error regarding the radio signals it shows „Code 05“.

When the device has been cut off from the mains the display will show the current software version upon first activation.

After a short period of time the display always switches back to the current humidity level.

## 9. Radio operation

The dehumidifier is available with or without a **radio sensor**.

An error in radio reception (no reception for 10 minutes) will be signaled in the display by the error code „05“. This code „05“ is also being displayed after every activation of the device until it receives a valid radio signal.



### ATTENTION !

**Never try to repair the device in case of malfunction!**

**Otherwise you will forfeit your warranty claim and risk damage to persons and the device.**

**Never intervene into the refrigerant circuit. This must only be done by qualified personnel.**

**This device contains the cooling agent R454C. It must not be allowed to escape into the atmosphere.**

## 10. Overheating protection

If the compressor heats up to more than 80°C during operation it is being shut off and only re-engaged once it has cooled down to 50°C.

## 11. Keylock

To prevent accidental input and to protect the device from unauthorized access it is equipped with a keylock.

To activate this keylock hold down the buttons „+ % RH“ and „- % RH“ simultaneously for about 5 seconds until an acoustic confirmation. During activation the display shows „88“. To release the lock repeat this process.

When a key is being pressed while the keylock is active the display again shows „88“.

## 12. Operating hours counter

The **DEHUMID HP 50** is fitted with an operating hours counter.

It is located on the back of the humidifier, above the water tanks.

It measures the time in hours during which the device is in operation.

## 13. Emptying the water tanks

Once the water tanks are filled to their maximum the device will stop to operate and on the control panel the LED „FULL“ lights up.

In addition an acoustic warning signal will sound (3 times for 1 second). This will be repeated every 5 minutes for a total of 60 minutes, when the acoustic warning will be shut off.

To put the device back into operation you have to perform the following steps:

- Remove the water tanks from the device. (The water tanks are located on the back of the device.)
- Empty the water tanks completely.
- Replace the water tanks back into the device.



Now the LED „FULL“ will go out and after a short period of time the device will resume operation.

## 14. Operation with direct drain hose

You can operate the **DEHUMID HP 50** without the water tanks, using a direct drain hose.

To activate the drain mode follow these steps:

- Remove the water tanks (on the backside)
- Turn off the device
- Unplug the mains
- Hold down the button „fan speed selector“ while plugging the mains back in.

The magnetic switches are now deactivated, which is indicated by the flashing LED „FULL“.

The device is now in direct drain mode and you can operate it with the drain hose.

As soon as the water tanks are being re-inserted, the drain mode is automatically being deactivated for safety reasons.



### ATTENTION !

**Make sure that the dehumidifier cannot be operated without a drain hose, once the magnetic switches have been deactivated, damage may occur.**

## 15. Maintenance



### ATTENTION !

**Always pull the mains plug before doing any maintenance work!**

**Never try to repair the device in case of malfunction!**

**Otherwise you will forfeit your warranty claim and risk damage to persons and the device.**

**Contact your retailer instead.**

#### 1) Cleaning the device

Use a damp cloth for cleaning the casing. Do not use aggressive cleaning agents.

**Make sure that no water gets into the device, since otherwise damage to it may occur.**

That is why you should never directly use a jet of water to clean the device.

#### 2) Cleaning/replacing the filters

There are two air filters located on the sides of the dehumidifier, one each for the intake and the exhaust. They filter out dust and other particles of the ambient air and thus must be cleaned regularly.

The air filters should be cleaned as necessary but at least once a month.

In order to remove the filters you should follow these steps:

- Remove the grating by unscrewing the screws (located as shown)
- Then remove the clamp bracket on the back of each grating by gently bending it outwards
- You can now remove the filter from the grating

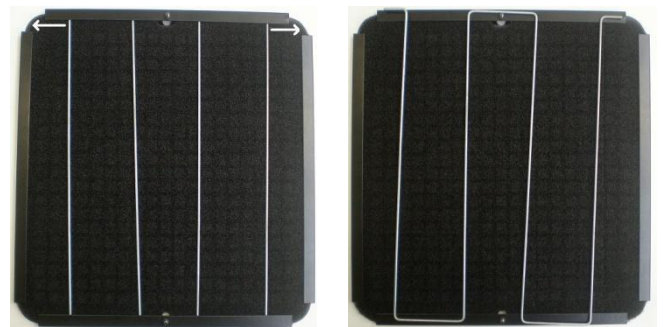

- Clean the filter by blowing it out / vacuuming it off or sluicing it down if applicable.
- In case cleaning the filter is not possible / sufficient or if the filter is damaged you should replace it.

## 16. Specifications

Model		DHI Pro 50
Nominal airflow (m <sup>3</sup> /H)	n= 1700 rpm	1065
	n= 1200 rpm	885
Supply voltage		220-240V ~50Hz
Power consumption *		1221 W
Range of application °C		+5 -32 °C
Range of application RH		30% - 90%
Weight		42 kg without tanks, 45 kg with tanks
Dimensions (WxHxD)		54 x 78 x 48 cm
Defrosting		Hot gas bypass
Refrigerant		0,65kg R454C (GWP=154; 0,095 tCO <sub>2</sub> e; ODP=0)
Drying capacity	27°C – 80%	45 ltrs/24h
	32°C – 80%	50 ltrs/24h
Operating hours counter		✓

\* at 32°C – 80% humidity

## 17. Troubleshooting

Trouble	Possible cause	Remedy
<b>Unit can't be switched on (LED „Standby“ doesn't light up)</b>	No power to the unit	Plug in the mains; check power at the outlet
	Main switch not in position „ON“	Switch on the unit
	Fuse is defective	Contact your retailer
<b>Unit is turned on but doesn't dehumidify (no water in the tanks)</b>	The ambient temperature is below +5°C	Under these conditions the operation of the device is inefficient. We recommend turning off the unit or raise the ambient temperature where possible.
	The ambient temperature exceeds +32 °C	Under these conditions the compressor of the dehumidifier is overloaded and the device automatically shuts down. We recommend turning off the dehumidifier.
	The humidity of the ambient air is below 30 % r.h.	Under these conditions the operation of the device is inefficient. We recommend turning off the unit.
	The air filters are dirty	Clean / replace the air filters.
	Not enough operating time yet	Keep the unit running and observe. It may be some time after switching on, before the water starts to collect in the tanks.

Trouble	Possible cause	Remedy
Device is dehumidifying but the ambient humidity remains constant	Room is too big	Employ an additional unit.
	Too many sources of humidity in the room	Remove sources if possible.
Unit is defrosting continuously, ice is visible on the evaporator.	The circuit board is defective	Contact your retailer.
	The ambient temperature is below +5°C	Make sure to only operate the unit in rooms with a temperature exceeding +5°C.
	The magnetic valve of the defrosting system is defective	Contact your retailer.
Automatic defrosting system is not operating	The temperature sensor is defective	Contact your retailer.
	The circuit board is defective	Contact your retailer.
	The magnetic valve of the defrosting system is defective	Contact your retailer.

## 18. Circuit diagram

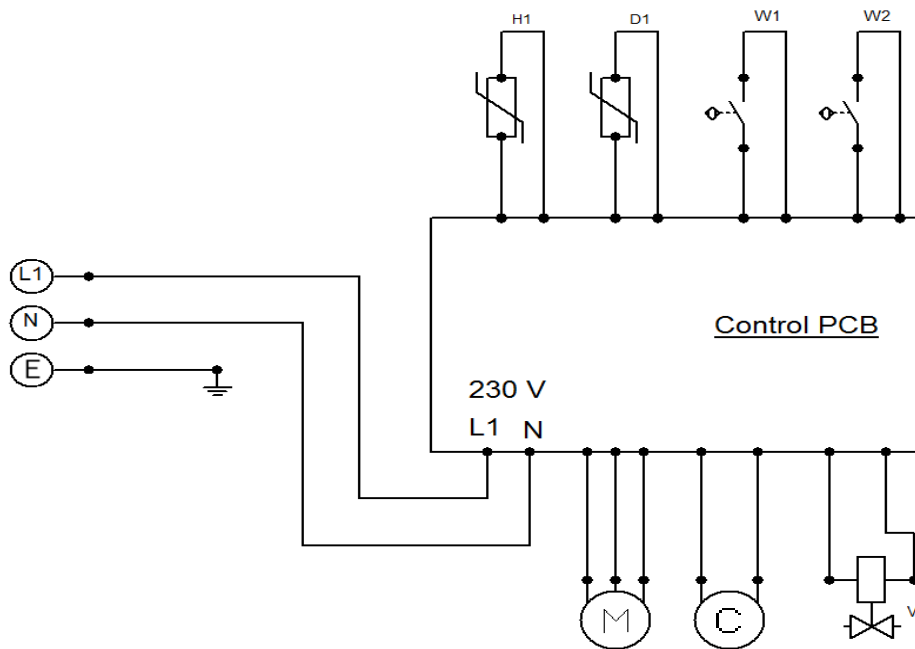

Item	Designation	Item	Designation
M	Motor fan	H1	Sensor for overheating protection
C	Compressor	D1	Defrosting sensor
v	Valve	<sup>w1</sup> / <sub>w2</sub>	Water level sensor

## 19. Exploded view

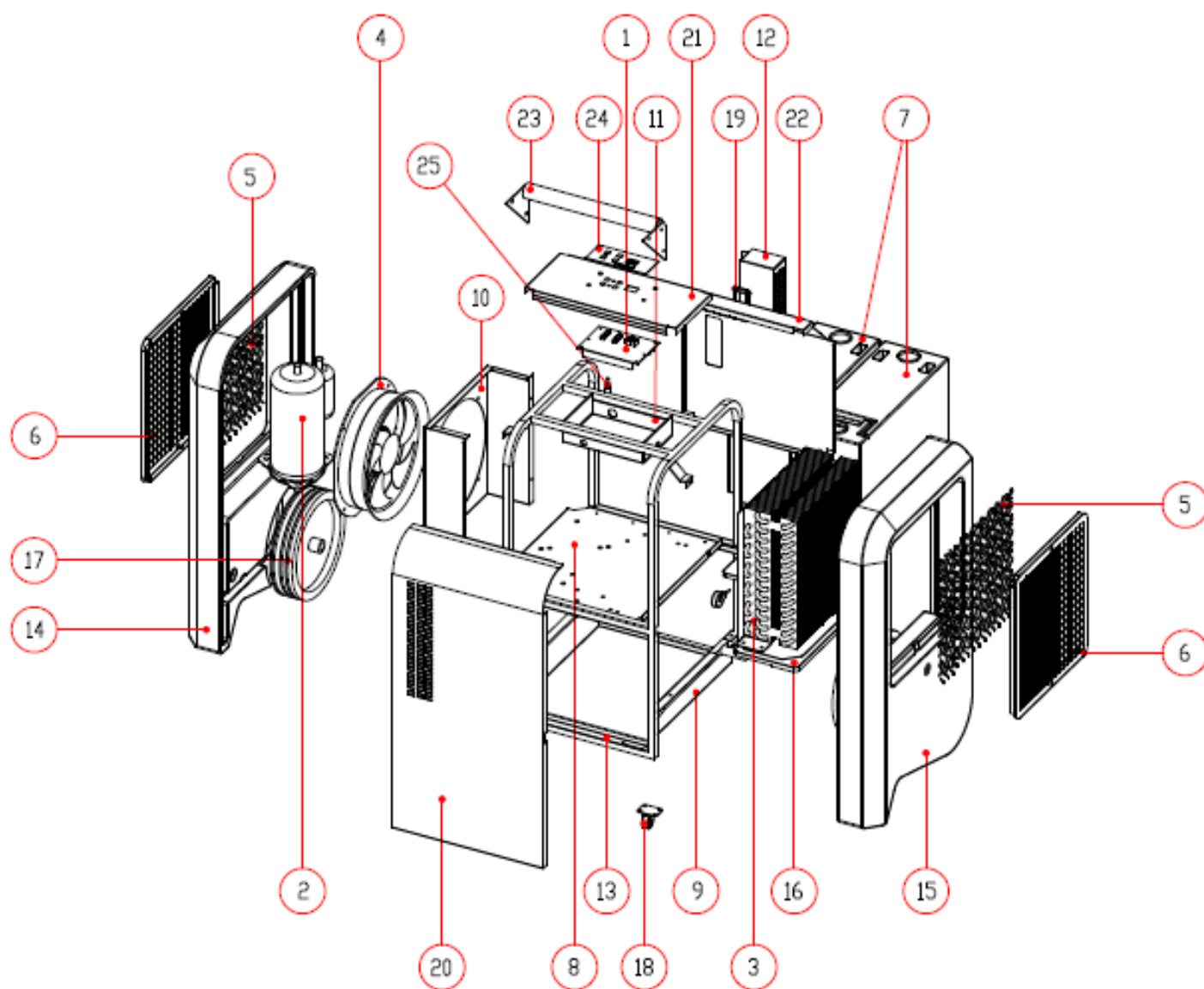

## 20. Subassemblies

Pos.	Benennung	Pos.	Benennung
1	Circuit board	14	Plastic cover left
2	Compressor	15	Plastic cover right
3	Evaporator	16	Water collection tub
4	Motor fan	17	Wheel
5	Air filter	18	Swivel caster
6	Grating / filter bracket	19	Plug holder
7	Water tank	20	Stainless steel front cover
8	Base plate	21	Stainless steel top cover
9	Support for water tanks	22	Stainless steel rear cover
10	Support for motor fan	23	Stainless steel handle
11	Support for circuit board	24	Operating panel
12	Cable housing	25	Wireless antenna
13	Structural frame		